

FORTRESS BUILDING PRODUCTS TEST REPORT

SCOPE OF WORK

STRUCTURAL PERFORMANCE TESTING ON THE *AL13 HOME* VERTICAL CABLE RAIL SYSTEM WITH ACCENT TOP RAIL (ATR)

REPORT NUMBER

P0710.01-119-19

TEST DATES

08/03/22 - 08/09/22

ISSUE DATE

11/15/22

RECORD RETENTION END DATE

08/09/26

PAGES

38

DOCUMENT CONTROL NUMBER

RT-R-AMER-Test-2846 (02/09/18)

© 2017 INTERTEK



TEST REPORT FOR FORTRESS BUILDING PRODUCTS

Report No.: P0710.01-119-19

Date: 11/15/22

REPORT ISSUED TO

FORTRESS BUILDING PRODUCTS

1720 North First Street

Suite B

Garland, TX 75040

SECTION 1

SCOPE

Architectural Testing, Inc. (an Intertek company) dba Intertek Building & Construction (B&C) was contracted by Fortress Building Products to perform structural performance testing in accordance with the 2020 National Building Code (NBC) of Canada and 2021 International Building Code (IBC) on their *A113 Home Vertical Cable Rail* aluminum guardrail system with accent top rail (ATR). This report is in conjunction with Intertek Report No. N8659.01-119-19 which includes structural performance testing of the 3 in square *A113 Home* post mount. Results obtained are tested values and were secured by using the designated test method(s). Testing was conducted at Intertek test facility in York, Pennsylvania. This report does not constitute certification of this product nor an opinion or endorsement by this laboratory.

Intertek B&C in York, Pennsylvania has demonstrated compliance with ISO/IEC International Standard 17025 and is consequently accredited as a Testing Laboratory (TL-144) by International Accreditation Service, Inc. (IAS). Intertek B&C is accredited to perform all testing reported herein.

This report does not constitute certification of this product nor an opinion or endorsement by this laboratory. Unless differently required, Intertek reports apply the "Simple Acceptance" rule, also called "Shared Risk approach," of ILAC-G8:09/2019, Guidelines on Decision Rules and Statements of Conformity. Intertek will service this report for the entire test record retention period. The test record retention period ends four years after the test date. Test records, such as detailed drawings, datasheets, representative samples of test specimens, or other pertinent project documentation, will be retained for the entire test record retention period.

For INTERTEK B&C:

COMPLETED BY:	Adam J. Schrum	REVIEWED BY:	V. Thomas Mickley, Jr., P.E.
TITLE:	Project Manager	TITLE:	Senior Staff Engineer
SIGNATURE:		SIGNATURE:	
DATE:	11/15/22	DATE:	11/15/22

AJS:vtm/aas

This report is for the exclusive use of Intertek's Client and is provided pursuant to the agreement between Intertek and its Client. Intertek's responsibility and liability are limited to the terms and conditions of the agreement. Intertek assumes no liability to any party, other than to the Client in accordance with the agreement, for any loss, expense or damage occasioned by the use of this report. Only the Client is authorized to permit copying or distribution of this report and then only in its entirety. Any use of the Intertek name or one of its marks for the sale or advertisement of the tested material, product or service must first be approved in writing by Intertek. The observations and test results in this report are relevant only to the sample(s) tested. This report by itself does not imply that the material, product, or service is or has ever been under an Intertek certification program.

TEST REPORT FOR FORTRESS BUILDING PRODUCTS

Report No.: P0710.01-119-19

Date: 11/15/22

SECTION 2

TEST METHODS

The specimens were evaluated in accordance with the following:

2021, *International Building Code*[®], International Code Council

2021, *International Residential Code*[®], International Code Council

2020, *National Building Code of Canada*

2017, *Ontario Building Code*

2018, *British Columbia Building Code*

2019, *Alberta Building Code*

Structural tests were performed according to Chapter 17 (Structural Tests and Special Inspections) of the 2021 *International Building Code*[®], International Code Council.

Limitations

All tests performed were to evaluate structural performance of the guardrail assembly to carry and transfer imposed loads to the supporting structure. The test specimens evaluated included the infill, rails, rail brackets, and support posts. Anchorage of support posts to the supporting structure is not included in the scope of this testing and would need to be evaluated separately.

Testing reported herein was performed using a safety factor of 2.5 x design load for NBC loads and IBC loads applied to the rail. Approval of the testing reported herein, and the use of the noted safety factor for the Canadian code is left up to the authority having jurisdiction.

SECTION 3

MATERIAL SOURCE/INSTALLATION

Test samples were provided by the client. Representative samples of the test specimens will be retained by Intertek B&C for a minimum of four years from the test completion date.

The guardrail assembly was installed and tested as a single railing section by surface mounting the posts to steel channels (simulated concrete). Transducers mounted to an independent reference frame were located to record movement of reference points on the guardrail system components (ends and mid-point) to determine net component deflections. See photographs in Section 10 for individual test setups.

TEST REPORT FOR FORTRESS BUILDING PRODUCTS

Report No.: P0710.01-119-19

Date: 11/15/22

SECTION 4 EQUIPMENT

The guardrail was tested in a self-contained structural frame designed to accommodate anchorage of the guardrail assembly and application of the required test loads. The specimens were loaded using an electric winch mounted to a rigid steel test frame. High strength steel cables, nylon straps, and load distribution beams were used to impose test loads on the specimens. Applied load was measured using an electronic load cell located in-line with the loading system. Electronic linear motion transducers were used to measure deflections.

SECTION 5 LIST OF OFFICIAL OBSERVERS

NAME	COMPANY
Adam J. Schrum	Intertek B&C
Scott A. McMaster	Intertek B&C

SECTION 6 TEST PROCEDURE

Each test specimen was inspected prior to testing to verify size and general condition of the materials, assembly, and installation. No potentially compromising defects were observed prior to testing.

An initial load, not exceeding 50% of design load, was applied and transducers were zeroed. Load was then applied at a steady uniform rate until reaching 2.0 times design load in no less than 10 seconds. After reaching 2.0 times design load, the load was released. After allowing a minimum period of one minute for stabilization, load was reapplied to the initial load level used at the start of the loading procedure, and deflections were recorded and used to analyze recovery. Load was then increased at a steady uniform rate until reaching 2.5 times design load or until failure occurred. The testing time was continually recorded from the application of initial test load until the ultimate test load was reached.

Deflection and permanent set were component deflections relative to their end-points; they were not overall system displacements. All loads and displacement measurements were horizontal, unless noted otherwise.

TEST REPORT FOR FORTRESS BUILDING PRODUCTS

Report No.: P0710.01-119-19

Date: 11/15/22

SECTION 7

TEST SPECIMEN DESCRIPTION

Test specimens were assembled by an Intertek technician. Fortress Railing Products provided the test components with the following details:

PRODUCT	<i>AL13 Home Vertical Cable Rail</i> guardrail system
MATERIAL	Extruded Aluminum (unspecified alloy)
COLORS	- Black - White
RAIL LENGTH	94 in (inside of post to inside of post)
RAIL HEIGHT	- 40-1/2 in (top of top rail to bottom of bottom rail) (level) - 42 in (nominal)
TOP RAIL CAP	- Flat: 1-5/8 in high by 2-3/8 in wide by 0.070 in thick aluminum extrusion - Round: 2-1/16 in high by 2-3/8 in wide by 0.070 in thick contoured aluminum extrusion
TOP RAIL SPACER	- 1-7/16 in high by 2-3/16 in wide by 0.050/0.040 in thick aluminum extrusion (continuous) (used in guardrail system with the Flat top rail) - 1-7/16 in high by 2-3/16 in wide by 1-3/4 in long by 0.070/0.060 in thick aluminum extrusion (spaced 2 in from each end and 15 in on center) (used in guardrail systems with the Round top rail)
TOP RAIL SUBRAIL/ BOTTOM RAIL	Vertical Cable System (Level): 1-1/4 in high by 1-1/4 in wide by 0.100 in thick "closed box" aluminum extrusion
IN-FILL	1/8 in diameter, 1x19, stainless steel vertical cables (twenty-one equally spaced in groups of three) with six equally spaced 5/8 in diameter by 0.125 in thick vertical intermediate support balusters
RAIL BRACKETS	1-1/2 in high by 1-5/8 in wide by 1 in deep (0.160/0.150 in wall) cast aluminum brackets
POST	<i>AL13 Home</i> : 3 in square by 0.120 in thick aluminum tube connected to a 5-1/2 in square by 0.40 in thick aluminum base plate with a 1/4 in continuous fillet weld; the base plate included four 7/16 in diameter holes and one 1 in diameter hole
SUPPORT FOOT	5/8 in square by 2 in high cast aluminum tube with cap plate (located at midpoint of the bottom rail)

TEST REPORT FOR FORTRESS BUILDING PRODUCTS

Report No.: P0710.01-119-19

Date: 11/15/22

Fastening Schedule

CONNECTION	FASTENER
Rail Bracket to Post	Two 1/4-14 by 1" (0.157 in minor diameter) Torx drive, flat-head, self-drilling, coated steel screws
Rail Bracket to Rail	Two #12-24 by 3/4" (0.181 in minor diameter) Torx drive, flat-head, thread cutting, coated steel screws
Rail Spacer to Rail	#10-16 by 1/2" (0.127 in minor diameter) hex head, self-drilling screws (two per piece, one protected side and one exterior side when spacer is non-continuous; 2 in from each end and 18 in on center staggered (protected side/exterior side) when spacer is continuous)
Intermediate Support Baluster to Top/Bottom Rail	One, 1/4-24 by 1-1/8", allen drive, pan-head, stainless steel machine screw with washer
Cable Infill to Top Rail	Stainless steel swage connector with 5/16 in threaded end, nylon lock nut and washer
Cable Infill to Bottom Rail	Stainless steel swage connector with snap ring
Top Rail Cap to Top Rail Spacer	Snap Fit - No mechanical connections
Support Block to Bottom Rail	Two #6-20 by 5/8" Philips drive, flat-head, coated steel screws
Steel Post Mount to Substructure	Four 3/8 in Grade 5 hex-head bolts with nut and washer

TEST REPORT FOR FORTRESS BUILDING PRODUCTS

Report No.: P0710.01-119-19

Date: 11/15/22

SECTION 8

TEST RESULTS

Key to Test Results Tables:

Load Level: Target test load

Test Load: Actual applied load at the designated load level (target).

Elapsed Time (E.T.): The amount of time into the test with zero established at the beginning of the loading procedure.

Test Series No. 1

8 ft (94 in) by 42 in A13 Home Level Guardrail with Vertical Cable Infill and Flat Profile ATR

Test No. 1 - 08/03/22

IBC Design Load: 50 lb / 1 Square ft at Center of In-fill (on 3 Cables) ¹

NBC Design Load: 112 lb / 11.81 Square in at Center of In-fill (on 3 Cables)

LOAD LEVEL	TEST LOAD (lb)	E.T. (min:sec)	DISPLACEMENT (in)			
			END	MID	END	NET
Initial Load	25	00:00	--	0.00	--	--
2.0x Design Load	101	00:19	--	0.78	--	--
Initial Load	25	01:38	--	0.03	--	--
96% Recovery from 2.0 x Design Load						
2.5x Design Load (IBC)	126	01:54	Achieved Load without Failure			
2.5x Design Load (NBC)	285	02:12				

¹ Load was applied through the worst case 11.81 square in loading plate.

Test No. 2 - 08/03/22

IBC Design Load: 50 lb / 1 Square ft at Bottom of In-fill (on 3 Cables) ¹

NBC Design Load: 112 lb / 11.81 Square in at Bottom of In-fill (on 3 Cables)

LOAD LEVEL	TEST LOAD (lb)	E.T. (min:sec)	DISPLACEMENT (in)			
			END	MID	END	NET
Initial Load	25	00:00	--	0.00	--	--
2.0x Design Load	102	00:27	--	0.78	--	--
Initial Load	25	01:53	--	0.00	--	--
100% Recovery from 2.0 x Design Load						
2.5x Design Load (IBC)	129	02:09	Achieved Load without Failure			
2.5x Design Load (NBC)	284	02:25				

¹ Load was applied through the worst case 11.81 square in loading plate.

TEST REPORT FOR FORTRESS BUILDING PRODUCTS

Report No.: P0710.01-119-19

Date: 11/15/22

Test No. 3 - 08/03/22

IBC Design Load: 50 lb / 1 Square ft at Center of In-fill (on Intermediate Baluster) ¹

NBC Design Load: 112 lb / 11.81 Square in at Center of In-fill (on Intermediate Baluster)

LOAD LEVEL	TEST LOAD (lb)	E.T. (min:sec)	DISPLACEMENT (in)			
			END	MID	END	NET
Initial Load	25	00:00	--	0.00	--	--
2.0x Design Load	102	00:17	--	0.62	--	--
Initial Load	25	01:48	--	0.07	--	--
89% Recovery from 2.0 x Design Load						
2.5x Design Load (IBC)	126	01:58	Achieved Load without Failure			
2.5x Design Load (NBC)	285	02:12				

¹ Load was applied through the worst case 11.81 square in loading plate.

Test No. 4 - 08/03/22

IBC Design Load: 50 lb / 1 Square ft at Bottom of In-fill (on Intermediate Baluster) ¹

NBC Design Load: 112 lb / 11.81 Square in at Bottom of In-fill (on Intermediate Baluster)

LOAD LEVEL	TEST LOAD (lb)	E.T. (min:sec)	DISPLACEMENT (in)			
			END	MID	END	NET
Initial Load	25	00:00	--	0.00	--	--
2.0x Design Load	101	00:12	--	0.62	--	--
Initial Load	25	01:41	--	0.00	--	--
100% Recovery from 2.0 x Design Load						
2.5x Design Load (IBC)	126	01:57	Achieved Load without Failure			
2.5x Design Load (NBC)	284	02:11				

¹ Load was applied through the worst case 11.81 square in loading plate.

TEST REPORT FOR FORTRESS BUILDING PRODUCTS

Report No.: P0710.01-119-19

Date: 11/15/22

Test No. 5 - 08/03/22

IBC Design Load: 50 plf x (94 ÷ 12 in/ft) = 391.7 lb Horizontal Uniform Load on Top Rail

NBC-Commercial Design Load: 51.4 plf x (94 ÷ 12 in/ft) = 402.6 lb Horizontal Uniform Load on Top Rail¹

LOAD LEVEL	TEST LOAD (lb)	E.T. (min:sec)	RAIL DISPLACEMENT (in)			
			END	MID	END	NET
Initial Load	75	00:00	0.00	0.00	0.00	0.00
2.0x Design Load (IBC)	788	00:45	1.24	2.58	1.19	1.37
Initial Load	75	02:25	0.09	0.18	0.13	0.07
95% Recovery from 2.0 x Design Load (IBC)						
2.5x Design Load (IBC)	982	03:05	Achieved Load without Failure			
2.5x Design Load (NBC)	1016	03:08				

¹ Uniform load was simulated with quarter-point loading.

Test No. 6 - 08/03/22

IBC Design Load: 50 plf x (94 ÷ 12 in/ft) = 391.7 lb Vertical Uniform Load on Top Rail

NBC-Commercial Design Load: 102.78 plf x (94 ÷ 12 in/ft) = 805.1 lb Vertical Uniform Load on Top Rail¹

LOAD LEVEL	TEST LOAD (lb)	E.T. (min:sec)	RAIL DISPLACEMENT (in)
Initial Load	75	00:00	0.00
2.0x Design Load (IBC)	784	00:37	0.16
Initial Load	75	02:15	0.01
94% Recovery from 2.0 x Design Load (IBC)			
2.5x Design Load (IBC)	981	02:52	Achieved Load without Failure
2.5x Design Load (NBC)	2014	03:24	

¹ Uniform load was simulated with four equal point loads.

TEST REPORT FOR FORTRESS BUILDING PRODUCTS

Report No.: P0710.01-119-19

Date: 11/15/22

Test No. 7 - 08/03/22

IRC Design Load: 200 lb Horizontal Concentrated Load at Midspan of Top Rail

NBC Design Load: 225 lb Horizontal Concentrated Load at Midspan of Top Rail

LOAD LEVEL	TEST LOAD (lb)	E.T. (min:sec)	RAIL DISPLACEMENT (in)			
			END	MID	END	NET ¹
Initial Load	50	00:00	0.00	0.00	0.00	0.00
2.0x Design Load (IRC)	406	00:46	0.56	1.56	0.55	1.01
Initial Load	50	02:13	0.00	0.00	0.00	0.00
100% Recovery from 2.0 x Design Load (IBC)						
2.5x Design Load (IBC)	507	02:41	Achieved Load without Failure			
2.5x Design Load (NBC)	574	02:45				

¹ Net displacement was mid-rail displacement relative to the rail at the support posts.

Test No. 8 - 08/03/22

IRC Design Load: 200 lb Vertical Concentrated Load at Midspan of Top Rail

NBC Design Load: 225 lb Vertical Concentrated Load at Midspan of Top Rail

LOAD LEVEL	TEST LOAD (lb)	E.T. (min:sec)	RAIL DISPLACEMENT (in)			
			END	MID	END	NET
Initial Load	50	00:00	--	0.00	--	--
2.0x Design Load (IRC)	405	00:26	--	0.05	--	--
Initial Load	50	02:02	--	0.01	--	--
80% Recovery from 2.0 x Design Load (IBC)						
2.5x Design Load (IBC)	501	02:26	Achieved Load without Failure			
2.5x Design Load (NBC)	567	02:30				

TEST REPORT FOR FORTRESS BUILDING PRODUCTS

Report No.: P0710.01-119-19

Date: 11/15/22

Test No. 9 - 08/03/22

IRC Design Load: 200 lb Horizontal Concentrated Load at Ends of Top Rail (Brackets)

NBC Design Load: 225 lb Horizontal Concentrated Load at Ends of Top Rail (Brackets)

LOAD LEVEL ¹	TEST LOAD (lb)	E.T. (min:sec)	RAIL DISPLACEMENT (in)	
			RAIL END #1	RAIL END #2
Initial Load	80	00:00	0.00	0.00
(2.0x Design Load) x 2 (IBC)	805	00:40	1.27	1.17
Initial Load	80	02:14	0.01	0.01
99% Recovery (Rail End #1) and 99% Recovery (Rail End #2) from 2.0 x Design Load (IBC)				
(2.5x Design Load) x 2 (IBC)	1008	02:46	Achieved Load without Failure	
(2.5x Design Load) x 2 (NBC)	1130	02:53		

¹ A spreader beam was used to impose loads on both ends of the railing system; therefore, loads were doubled.

Test No. 10 - 08/03/22

IRC Design Load: 200 lb Vertical Concentrated Load at Ends of Top Rail (Brackets)

NBC Design Load: 225 lb Vertical Concentrated Load at Ends of Top Rail (Brackets)

LOAD LEVEL ¹	TEST LOAD (lb)	E.T. (min:sec)	RAIL DISPLACEMENT (in)
Initial Load	80	00:00	0.00
(2.0x Design Load) x 2 (IBC)	801	00:33	0.05
Initial Load	80	02:03	0.00
100% Recovery from 2.0 x Design Load (IBC)			
(2.5x Design Load) x 2 (IBC)	1006	02:50	Achieved Load without Failure
(2.5x Design Load) x 2 (NBC)	1126	02:55	

¹ A spreader beam was used to impose loads on both ends of the railing system; therefore, loads were doubled.

TEST REPORT FOR FORTRESS BUILDING PRODUCTS

Report No.: P0710.01-119-19

Date: 11/15/22

Test Series No. 2

8 ft (94 in) by 42 in A113 Home Level Guardrail with Vertical Cable Infill and Round Profile ATR

Test Specimen No. 1 of 3

Test No. 1 - 08/04/22

IBC Design Load: 50 lb / 1 Square ft at Center of In-fill (on 3 Cables) ¹

NBC Design Load: 112 lb / 11.81 Square in at Center of In-fill (on 3 Cables)

LOAD LEVEL	TEST LOAD (lb)	E.T. (min:sec)	DISPLACEMENT (in)			
			END	MID	END	NET
Initial Load	50	00:00	--	0.00	--	--
2.0x Design Load	101	00:13	--	0.49	--	--
Initial Load	50	01:36	--	0.02	--	--
96% Recovery from 2.0 x Design Load						
2.5x Design Load (IBC)	126	01:47	Achieved Load without Failure			
2.5x Design Load (NBC)	286	02:03				

¹ Load was applied through the worst case 11.81 square in loading plate.

Test No. 2 - 08/04/22

IBC Design Load: 50 lb / 1 Square ft at Bottom of In-fill (on 3 Cables) ¹

NBC Design Load: 112 lb / 11.81 Square in at Bottom of In-fill (on 3 Cables)

LOAD LEVEL	TEST LOAD (lb)	E.T. (min:sec)	DISPLACEMENT (in)			
			END	MID	END	NET
Initial Load	25	00:00	--	0.00	--	--
2.0x Design Load	106	00:20	--	0.88	--	--
Initial Load	25	01:49	--	0.00	--	--
100% Recovery from 2.0 x Design Load						
2.5x Design Load (IBC)	132	02:04	Achieved Load without Failure			
2.5x Design Load (NBC)	287	02:16				

¹ Load was applied through the worst case 11.81 square in loading plate.

TEST REPORT FOR FORTRESS BUILDING PRODUCTS

Report No.: P0710.01-119-19

Date: 11/15/22

Test No. 3 - 08/04/22

IBC Design Load: 50 lb / 1 Square ft at Center of In-fill (on Intermediate Baluster) ¹

NBC Design Load: 112 lb / 11.81 Square in at Center of In-fill (on Intermediate Baluster)

LOAD LEVEL	TEST LOAD (lb)	E.T. (min:sec)	DISPLACEMENT (in)			
			END	MID	END	NET
Initial Load	25	00:00	--	0.00	--	--
2.0x Design Load	104	00:14	--	0.68	--	--
Initial Load	25	01:42	--	0.01	--	--
99% Recovery from 2.0 x Design Load						
2.5x Design Load (IBC)	127	01:53	Achieved Load without Failure			
2.5x Design Load (NBC)	285	02:03				

¹ Load was applied through the worst case 11.81 square in loading plate.

Test No. 4 - 08/04/22

IBC Design Load: 50 lb / 1 Square ft at Bottom of In-fill (on 1 Baluster) ¹

NBC Design Load: 112 lb / 11.81 Square in at Bottom of In-fill (on 1 Baluster)

LOAD LEVEL	TEST LOAD (lb)	E.T. (min:sec)	DISPLACEMENT (in)			
			END	MID	END	NET
Initial Load	25	00:00	--	0.00	--	--
2.0x Design Load	103	00:12	--	0.69	--	--
Initial Load	25	01:29	--	0.02	--	--
97% Recovery from 2.0 x Design Load						
2.5x Design Load (IBC)	125	01:38	Achieved Load without Failure			
2.5x Design Load (NBC)	287	01:49				

¹ Load was applied through the worst case 11.81 square in loading plate.

Test No. 5 - 08/04/22

IBC Design Load: 50 plf x (94 ÷ 12 in/ft) = 391.7 lb Horizontal Uniform Load on Top Rail

NBC-Commercial Design Load: 51.4 plf x (94 ÷ 12 in/ft) = 402.6 lb Horizontal Uniform Load on Top Rail ¹

LOAD LEVEL	TEST LOAD (lb)	E.T. (min:sec)	RAIL DISPLACEMENT (in)			
			END	MID	END	NET
Initial Load	75	00:00	0.00	0.00	0.00	0.00
2.0x Design Load (IBC)	792	00:34	1.14	2.95	1.14	1.81
Initial Load	75	02:06	0.10	0.21	0.09	0.12
93% Recovery from 2.0 x Design Load (IBC)						
2.5x Design Load (IBC)	984	02:40	Achieved Load without Failure			
2.5x Design Load (NBC)	1010	02:43				

¹ Uniform load was simulated with quarter-point loading.

TEST REPORT FOR FORTRESS BUILDING PRODUCTS

Report No.: P0710.01-119-19

Date: 11/15/22

Test No. 6 - 08/04/22

IBC Design Load: 50 plf x (94 ÷ 12 in/ft) = 391.7 lb Vertical Uniform Load on Top Rail

NBC-Commercial Design Load: 102.78 plf x (94 ÷ 12 in/ft) = 805.1 lb Vertical Uniform Load on Top Rail¹

LOAD LEVEL	TEST LOAD (lb)	E.T. (min:sec)	RAIL DISPLACEMENT (in)
Initial Load	75	00:00	0.00
2.0x Design Load (IBC)	794	00:25	0.10
Initial Load	75	01:44	0.02
80% Recovery from 2.0 x Design Load (IBC)			
2.5x Design Load (IBC)	980	02:16	Achieved Load without Failure
2.5x Design Load (NBC)	2033	02:36	

¹ Uniform load was simulated with four equal point loads.

Test No. 7 - 08/04/22

IRC Design Load: 200 lb Horizontal Concentrated Load at Midspan of Top Rail

NBC Design Load: 225 lb Horizontal Concentrated Load at Midspan of Top Rail

LOAD LEVEL	TEST LOAD (lb)	E.T. (min:sec)	RAIL DISPLACEMENT (in)			
			END	MID	END	NET ¹
Initial Load	50	00:00	0.00	0.00	0.00	0.00
2.0x Design Load (IRC)	406	00:29	0.51	1.91	0.56	1.38
Initial Load	50	01:57	0.00	0.01	0.00	0.01
99% Recovery from 2.0 x Design Load (IBC)						
2.5x Design Load (IBC)	500	02:22	Achieved Load without Failure			
2.5x Design Load (NBC)	564	02:26				

¹ Net displacement was mid-rail displacement relative to the rail at the support posts.

TEST REPORT FOR FORTRESS BUILDING PRODUCTS

Report No.: P0710.01-119-19

Date: 11/15/22

Test No. 8 - 08/04/22

IRC Design Load: 200 lb Vertical Concentrated Load at Midspan of Top Rail

NBC Design Load: 225 lb Vertical Concentrated Load at Midspan of Top Rail

LOAD LEVEL	TEST LOAD (lb)	E.T. (min:sec)	RAIL DISPLACEMENT (in)			
			END	MID	END	NET
Initial Load	50	00:00	--	0.00	--	--
2.0x Design Load (IRC)	416	00:15	--	0.08	--	--
Initial Load	50	01:58	--	0.01	--	--
88% Recovery from 2.0 x Design Load (IBC)						
2.5x Design Load (IBC)	521	02:07	Achieved Load without Failure			
2.5x Design Load (NBC)	579	02:10				

Test No. 9 - 08/04/22

IRC Design Load: 200 lb Horizontal Concentrated Load at Ends of Top Rail (Brackets)

NBC Design Load: 225 lb Horizontal Concentrated Load at Ends of Top Rail (Brackets)

LOAD LEVEL ¹	TEST LOAD (lb)	E.T. (min:sec)	RAIL DISPLACEMENT (in)	
			RAIL END #1	RAIL END #2
Initial Load	80	00:00	0.00	0.00
(2.0x Design Load) x 2 (IBC)	806	00:31	1.14	1.18
Initial Load	80	02:16	0.01	0.02
99% Recovery (Rail End #1) and 98% Recovery (Rail End #2) from 2.0 x Design Load (IBC)				
(2.5x Design Load) x 2 (IBC)	1001	02:43	Achieved Load without Failure	
(2.5x Design Load) x 2 (NBC)	1133	02:51		

¹ A spreader beam was used to impose loads on both ends of the railing system; therefore, loads were doubled.

Test No. 10 - 08/04/22

IRC Design Load: 200 lb Vertical Concentrated Load at Ends of Top Rail (Brackets)

NBC Design Load: 225 lb Vertical Concentrated Load at Ends of Top Rail (Brackets)

LOAD LEVEL ¹	TEST LOAD (lb)	E.T. (min:sec)	RAIL DISPLACEMENT (in)
Initial Load	80	00:00	0.00
(2.0x Design Load) x 2 (IBC)	807	00:33	0.05
Initial Load	80	02:13	0.01
80% Recovery from 2.0 x Design Load (IBC)			
(2.5x Design Load) x 2 (IBC)	1003	02:33	Achieved Load without Failure
(2.5x Design Load) x 2 (NBC)	1134	02:38	

¹ A spreader beam was used to impose loads on both ends of the railing system; therefore, loads were doubled.

TEST REPORT FOR FORTRESS BUILDING PRODUCTS

Report No.: P0710.01-119-19

Date: 11/15/22

Test Specimen No. 2 of 3

Test No. 1 - 08/05/22

IBC Design Load: 50 lb / 1 Square ft at Center of In-fill (on 3 Cables) ¹

NBC Design Load: 112 lb / 11.81 Square in at Center of In-fill (on 3 Cables)

LOAD LEVEL	TEST LOAD (lb)	E.T. (min:sec)	DISPLACEMENT (in)			
			END	MID	END	NET
Initial Load	25	00:00	--	0.00	--	--
2.0x Design Load	106	00:12	--	0.86	--	--
Initial Load	25	01:37	--	0.02	--	--
98% Recovery from 2.0 x Design Load						
2.5x Design Load (IBC)	127	01:50	Achieved Load without Failure			
2.5x Design Load (NBC)	283	02:04				

¹ Load was applied through the worst case 11.81 square in loading plate.

Test No. 2 - 08/05/22

IBC Design Load: 50 lb / 1 Square ft at Bottom of In-fill (on 3 Cables) ¹

NBC Design Load: 112 lb / 11.81 Square in at Bottom of In-fill (on 3 Cables)

LOAD LEVEL	TEST LOAD (lb)	E.T. (min:sec)	DISPLACEMENT (in)			
			END	MID	END	NET
Initial Load	25	00:00	--	0.00	--	--
2.0x Design Load	104	00:20	--	0.85	--	--
Initial Load	25	01:31	--	0.01	--	--
99% Recovery from 2.0 x Design Load						
2.5x Design Load (IBC)	130	01:51	Achieved Load without Failure			
2.5x Design Load (NBC)	289	02:01				

¹ Load was applied through the worst case 11.81 square in loading plate.

Test No. 3 - 08/05/22

IBC Design Load: 50 lb / 1 Square ft at Center of In-fill (on 1 Baluster) ¹

NBC Design Load: 112 lb / 11.81 Square in at Center of In-fill (on Intermediate Baluster)

LOAD LEVEL	TEST LOAD (lb)	E.T. (min:sec)	DISPLACEMENT (in)			
			END	MID	END	NET
Initial Load	25	00:00	--	0.00	--	--
2.0x Design Load	103	00:15	--	0.69	--	--
Initial Load	25	01:34	--	0.00	--	--
100% Recovery from 2.0 x Design Load						
2.5x Design Load (IBC)	126	01:42	Achieved Load without Failure			
2.5x Design Load (NBC)	285	01:55				

¹ Load was applied through the worst case 11.81 square in loading plate.

TEST REPORT FOR FORTRESS BUILDING PRODUCTS

Report No.: P0710.01-119-19

Date: 11/15/22

Test No. 4 - 08/05/22

IBC Design Load: 50 lb / 1 Square ft at Bottom of In-fill (on 1 Baluster) ¹

NBC Design Load: 112 lb / 11.81 Square in at Bottom of In-fill (on Intermediate Baluster)

LOAD LEVEL	TEST LOAD (lb)	E.T. (min:sec)	DISPLACEMENT (in)			
			END	MID	END	NET
Initial Load	25	00:00	--	0.00	--	--
2.0x Design Load	103	00:11	--	0.73	--	--
Initial Load	25	01:24	--	0.03	--	--
96% Recovery from 2.0 x Design Load						
2.5x Design Load (IBC)	129	01:42	Achieved Load without Failure			
2.5x Design Load (NBC)	286	01:54				

¹ Load was applied through the worst case 11.81 square in loading plate.

Test No. 5 - 08/05/22

IBC Design Load: 50 plf x (94 ÷ 12 in/ft) = 391.7 lb Horizontal Uniform Load on Top Rail

NBC-Commercial Design Load: 51.4 plf x (94 ÷ 12 in/ft) = 402.6 lb Horizontal Uniform Load on Top Rail ¹

LOAD LEVEL	TEST LOAD (lb)	E.T. (min:sec)	RAIL DISPLACEMENT (in)			
			END	MID	END	NET
Initial Load	75	00:00	0.00	0.00	0.00	0.00
2.0x Design Load (IBC)	796	00:41	1.38	3.00	1.18	1.72
Initial Load	75	02:15	0.12	0.21	0.12	0.09
95% Recovery from 2.0 x Design Load (IBC)						
2.5x Design Load (IBC)	985	02:51	Achieved Load without Failure			
2.5x Design Load (NBC)	1014	02:52				

¹ Uniform load was simulated with quarter-point loading.

Test No. 6 - 08/05/22

IBC Design Load: 50 plf x (94 ÷ 12 in/ft) = 391.7 lb Vertical Uniform Load on Top Rail

NBC-Commercial Design Load: 102.78 plf x (94 ÷ 12 in/ft) = 805.1 lb Vertical Uniform Load on Top Rail ¹

LOAD LEVEL	TEST LOAD (lb)	E.T. (min:sec)	RAIL DISPLACEMENT (in)
Initial Load	75	00:00	0.00
2.0x Design Load (IBC)	799	00:40	0.09
Initial Load	75	02:18	0.01
89% Recovery from 2.0 x Design Load (IBC)			
2.5x Design Load (IBC)	1000	02:45	Achieved Load without Failure
2.5x Design Load (NBC)	2021	03:11	

¹ Uniform load was simulated with four equal point loads.

TEST REPORT FOR FORTRESS BUILDING PRODUCTS

Report No.: P0710.01-119-19

Date: 11/15/22

Test No. 7 - 08/05/22

IRC Design Load: 200 lb Horizontal Concentrated Load at Midspan of Top Rail

NBC Design Load: 225 lb Horizontal Concentrated Load at Midspan of Top Rail

LOAD LEVEL	TEST LOAD (lb)	E.T. (min:sec)	RAIL DISPLACEMENT (in)			
			END	MID	END	NET ¹
Initial Load	50	00:00	0.00	0.00	0.00	0.00
2.0x Design Load (IRC)	407	00:34	0.59	1.84	0.53	1.28
Initial Load	50	02:10	0.00	0.01	0.00	0.01
99% Recovery from 2.0 x Design Load (IBC)						
2.5x Design Load (IBC)	500	02:38	Achieved Load without Failure			
2.5x Design Load (NBC)	565	02:43				

¹ Net displacement was mid-rail displacement relative to the rail at the support posts.

Test No. 8 - 08/05/22

IRC Design Load: 200 lb Vertical Concentrated Load at Midspan of Top Rail

NBC Design Load: 225 lb Vertical Concentrated Load at Midspan of Top Rail

LOAD LEVEL	TEST LOAD (lb)	E.T. (min:sec)	RAIL DISPLACEMENT (in)			
			END	MID	END	NET
Initial Load	50	00:00	--	0.00	--	--
2.0x Design Load (IRC)	402	00:48	--	0.06	--	--
Initial Load	50	02:17	--	0.00	--	--
100% Recovery from 2.0 x Design Load (IBC)						
2.5x Design Load (IBC)	505	03:12	Achieved Load without Failure			
2.5x Design Load (NBC)	565	03:15				

Test No. 9 - 08/05/22

IRC Design Load: 200 lb Horizontal Concentrated Load at Ends of Top Rail (Brackets)

NBC Design Load: 225 lb Horizontal Concentrated Load at Ends of Top Rail (Brackets)

LOAD LEVEL ¹	TEST LOAD (lb)	E.T. (min:sec)	RAIL DISPLACEMENT (in)	
			RAIL END #1	RAIL END #2
Initial Load	80	00:00	0.00	0.00
(2.0x Design Load) x 2 (IBC)	810	00:32	1.31	1.16
Initial Load	80	02:00	0.00	0.00
100% Recovery (Rail End #1) and 100% Recovery (Rail End #2) from 2.0 x Design Load (IBC)				
(2.5x Design Load) x 2 (IBC)	1008	02:25	Achieved Load without Failure	
(2.5x Design Load) x 2 (NBC)	1132	02:37		

¹ A spreader beam was used to impose loads on both ends of the railing system; therefore, loads were doubled.

TEST REPORT FOR FORTRESS BUILDING PRODUCTS

Report No.: P0710.01-119-19

Date: 11/15/22

Test No. 10 - 08/05/22

IRC Design Load: 200 lb Vertical Concentrated Load at Ends of Top Rail (Brackets)

NBC Design Load: 225 lb Vertical Concentrated Load at Ends of Top Rail (Brackets)

LOAD LEVEL ¹	TEST LOAD (lb)	E.T. (min:sec)	RAIL DISPLACEMENT (in)
Initial Load	80	00:00	0.00
(2.0x Design Load) x 2 (IBC)	802	00:34	0.07
Initial Load	80	02:10	0.00
100% Recovery from 2.0 x Design Load (IBC)			
(2.5x Design Load) x 2 (IBC)	1002	02:29	Achieved Load without Failure
(2.5x Design Load) x 2 (NBC)	1130	02:45	

¹ A spreader beam was used to impose loads on both ends of the railing system; therefore, loads were doubled.

Test Specimen No. 3 of 3

Test No. 1 - 08/08/22

IBC Design Load: 50 lb / 1 Square ft at Center of In-fill (on 3 Cables) ¹

NBC Design Load: 112 lb / 11.81 Square in at Center of In-fill (on 3 Cables)

LOAD LEVEL	TEST LOAD (lb)	E.T. (min:sec)	DISPLACEMENT (in)			
			END	MID	END	NET
Initial Load	25	00:00	--	0.00	--	--
2.0x Design Load	105	00:12	--	0.78	--	--
Initial Load	25	01:33	--	0.02	--	--
97% Recovery from 2.0 x Design Load						
2.5x Design Load (IBC)	127	01:42	Achieved Load without Failure			
2.5x Design Load (NBC)	286	01:55				

¹ Load was applied through the worst case 11.81 square in loading plate.

Test No. 2 - 08/08/22

IBC Design Load: 50 lb / 1 Square ft at Bottom of In-fill (on 3 Cables) ¹

NBC Design Load: 112 lb / 11.81 Square in at Bottom of In-fill (on 3 Cables)

LOAD LEVEL	TEST LOAD (lb)	E.T. (min:sec)	DISPLACEMENT (in)			
			END	MID	END	NET
Initial Load	25	00:00	--	0.00	--	--
2.0x Design Load	103	00:18	--	0.80	--	--
Initial Load	25	01:38	--	0.01	--	--
99% Recovery from 2.0 x Design Load						
2.5x Design Load (IBC)	131	01:52	Achieved Load without Failure			
2.5x Design Load (NBC)	300	02:01				

¹ Load was applied through the worst case 11.81 square in loading plate.

TEST REPORT FOR FORTRESS BUILDING PRODUCTS

Report No.: P0710.01-119-19

Date: 11/15/22

Test No. 3 - 08/08/22

IBC Design Load: 50 lb / 1 Square ft at Center of In-fill (on 1 Baluster) ¹

NBC Design Load: 112 lb / 11.81 Square in at Center of In-fill (on Intermediate Baluster)

LOAD LEVEL	TEST LOAD (lb)	E.T. (min:sec)	DISPLACEMENT (in)			
			END	MID	END	NET
Initial Load	25	00:00	--	0.00	--	--
2.0x Design Load	103	00:12	--	0.68	--	--
Initial Load	25	01:36	--	0.03	--	--
96% Recovery from 2.0 x Design Load						
2.5x Design Load (IBC)	132	01:44	Achieved Load without Failure			
2.5x Design Load (NBC)	288	01:51				

¹ Load was applied through the worst case 11.81 square in loading plate.

Test No. 4 - 08/08/22

IBC Design Load: 50 lb / 1 Square ft at Bottom of In-fill (on 1 Baluster) ¹

NBC Design Load: 112 lb / 11.81 Square in at Bottom of In-fill (on Intermediate Baluster)

LOAD LEVEL	TEST LOAD (lb)	E.T. (min:sec)	DISPLACEMENT (in)			
			END	MID	END	NET
Initial Load	25	00:00	--	0.00	--	--
2.0x Design Load	100	00:14	--	0.68	--	--
Initial Load	25	01:32	--	0.01	--	--
99% Recovery from 2.0 x Design Load						
2.5x Design Load (IBC)	130	01:41	Achieved Load without Failure			
2.5x Design Load (NBC)	298	01:52				

¹ Load was applied through the worst case 11.81 square in loading plate.

Test No. 5 - 08/08/22

IBC Design Load: 50 plf x (94 ÷ 12 in/ft) = 391.7 lb Horizontal Uniform Load on Top Rail

NBC-Commercial Design Load: 51.4 plf x (94 ÷ 12 in/ft) = 402.6 lb Horizontal Uniform Load on Top Rail ¹

LOAD LEVEL	TEST LOAD (lb)	E.T. (min:sec)	RAIL DISPLACEMENT (in)			
			END	MID	END	NET
Initial Load	75	00:00	0.00	0.00	0.00	0.00
2.0x Design Load (IBC)	792	00:41	1.20	2.56	1.17	1.38
Initial Load	75	02:18	0.08	0.14	0.08	0.06
96% Recovery from 2.0 x Design Load (IBC)						
2.5x Design Load (IBC)	981	02:54	Achieved Load without Failure			
2.5x Design Load (NBC)	1018	02:56				

¹ Uniform load was simulated with quarter-point loading.

TEST REPORT FOR FORTRESS BUILDING PRODUCTS

Report No.: P0710.01-119-19

Date: 11/15/22

Test No. 6 - 08/08/22

IBC Design Load: 50 plf x (94 ÷ 12 in/ft) = 391.7 lb Vertical Uniform Load on Top Rail

NBC-Commercial Design Load: 102.78 plf x (94 ÷ 12 in/ft) = 805.1 lb Vertical Uniform Load on Top Rail¹

LOAD LEVEL	TEST LOAD (lb)	E.T. (min:sec)	RAIL DISPLACEMENT (in)
Initial Load	75	00:00	0.00
2.0x Design Load (IBC)	805	00:43	0.05
Initial Load	75	02:08	0.01
80% Recovery from 2.0 x Design Load (IBC)			
2.5x Design Load (IBC)	982	02:35	Achieved Load without Failure
2.5x Design Load (NBC)	2020	03:08	

¹ Uniform load was simulated with four equal point loads.

Test No. 7 - 08/08/22

IRC Design Load: 200 lb Horizontal Concentrated Load at Midspan of Top Rail

NBC Design Load: 225 lb Horizontal Concentrated Load at Midspan of Top Rail

LOAD LEVEL	TEST LOAD (lb)	E.T. (min:sec)	RAIL DISPLACEMENT (in)			
			END	MID	END	NET ¹
Initial Load	50	00:00	0.00	0.00	0.00	0.00
2.0x Design Load (IRC)	406	00:29	0.60	1.56	0.54	0.99
Initial Load	50	02:00	0.00	0.01	0.00	0.01
99% Recovery from 2.0 x Design Load (IBC)						
2.5x Design Load (IBC)	507	02:27	Achieved Load without Failure			
2.5x Design Load (NBC)	566	02:31				

¹ Net displacement was mid-rail displacement relative to the rail at the support posts.

Test No. 8 - 08/08/22

IRC Design Load: 200 lb Vertical Concentrated Load at Midspan of Top Rail

NBC Design Load: 225 lb Vertical Concentrated Load at Midspan of Top Rail

LOAD LEVEL	TEST LOAD (lb)	E.T. (min:sec)	RAIL DISPLACEMENT (in)			
			END	MID	END	NET
Initial Load	50	00:00	--	0.00	--	--
2.0x Design Load (IRC)	400	00:24	--	0.05	--	--
Initial Load	50	01:48	--	0.00	--	--
100% Recovery from 2.0 x Design Load (IBC)						
2.5x Design Load (IBC)	501	02:05	Achieved Load without Failure			
2.5x Design Load (NBC)	568	02:08				

TEST REPORT FOR FORTRESS BUILDING PRODUCTS

Report No.: P0710.01-119-19

Date: 11/15/22

Test No. 9 - 08/08/22

IRC Design Load: 200 lb Horizontal Concentrated Load at Ends of Top Rail (Brackets)

NBC Design Load: 225 lb Horizontal Concentrated Load at Ends of Top Rail (Brackets)

LOAD LEVEL ¹	TEST LOAD (lb)	E.T. (min:sec)	RAIL DISPLACEMENT (in)	
			RAIL END #1	RAIL END #2
Initial Load	80	00:00	0.00	0.00
(2.0x Design Load) x 2 (IBC)	803	00:47	1.25	1.25
Initial Load	80	02:31	0.00	0.01
100% Recovery (Rail End #1) and 99% Recovery (Rail End #2) from 2.0 x Design Load (IBC)				
(2.5x Design Load) x 2 (IBC)	1010	02:58	Achieved Load without Failure	
(2.5x Design Load) x 2 (NBC)	1131	03:07		

¹ A spreader beam was used to impose loads on both ends of the railing system; therefore, loads were doubled.

Test No. 10 - 08/08/22

IRC Design Load: 200 lb Vertical Concentrated Load at Ends of Top Rail (Brackets)

NBC Design Load: 225 lb Vertical Concentrated Load at Ends of Top Rail (Brackets)

LOAD LEVEL ¹	TEST LOAD (lb)	E.T. (min:sec)	RAIL DISPLACEMENT (in)
Initial Load	80	00:00	0.00
(2.0x Design Load) x 2 (IBC)	810	00:22	0.04
Initial Load	80	01:33	0.00
100% Recovery from 2.0 x Design Load (IBC)			
(2.5x Design Load) x 2 (IBC)	1014	01:57	Achieved Load without Failure
(2.5x Design Load) x 2 (NBC)	1126	02:01	

¹ A spreader beam was used to impose loads on both ends of the railing system; therefore, loads were doubled.

Test Series No. 3

Infill Spreader/100mm Sphere Passage Test at Midspan of Baluster ¹

TEST NO.	LOCATION	FORCE (lb)
1	Cable Baluster and Cable Baluster	10
2	Cable Baluster and Post Mount	11
3	Cable Baluster and Intermediate Baluster	>30

¹ The authority having jurisdiction shall determine if the loads meet the requirements of the provincial codes for the specific project location.

TEST REPORT FOR FORTRESS BUILDING PRODUCTS

Report No.: P0710.01-119-19

Date: 11/15/22

SECTION 9

CONCLUSION

Using performance criteria of withstanding an ultimate load of 2.5 times design load, the test results substantiate compliance with the design load requirements for One- and Two-Family Dwellings (IRC) for the *A113 Home Vertical Cable* railing assembly reported herein.

Using performance criteria of withstanding an ultimate load of 2.5 times design load, the test results substantiate compliance with the design load requirements for All Use Groups (IBC) for the guardrails detailed in the following table:

GUARDRAIL SYSTEM	GUARDRAIL TYPE	BALUSTER	SUPPORT POST ³	ALLOWABLE CENTER-TO-CENTER POST SPACING ^{1, 2}
<i>A113 Home</i> w/ Flat or Round ATR	Level / In-Line Application	Vertical Cables with Intermediate Baluster	3 in Square <i>A113 Home</i> Post Mount	6 ft - 5 in

¹ Allowable post spacing (center-to-center of post) = Ultimate load (post mount) / (50 plf x 2.5 safety factor).

² Center-to-center spacing is based on post strength noted in Intertek report No. N8659.01-119-19. Allowable post spacing shall not exceed the lesser of the noted center-to-center post spacing or the allowable length of the guardrail to which it is attached.

³ Maximum guardrail height for both IRC and IBC applications is 42 in; post mounts reported herein have not been evaluated for guardrail heights more than 42 in.

TEST REPORT FOR FORTRESS BUILDING PRODUCTS

Report No.: P0710.01-119-19

Date: 11/15/22

Using performance criteria of withstanding an ultimate load of 2.5 times design load, the test results substantiate compliance with the design load requirements for NBCC, OBC, BCBC and ABC for the guardrails detailed in the following tables:

Application: Guards Serving Not More than 2 Dwelling Units ⁶

GUARDRAIL SYSTEM	GUARDRAIL TYPE	BALUSTER	SUPPORT POST ⁴	REQUIREMENTS ⁵	
				CONCENTRATED LOAD ³	UNIFORM LOAD ^{1, 2} ALLOWABLE CENTER-TO-CENTER POST SPACING
A/13 Home w/ Flat or Round ATR	Level / In-Line Application	Vertical Cables with Intermediate Baluster	3 in Square A/13 Home Post Mount	Meets the requirements	9 ft - 5 in

¹ Allowable post spacing (center-to-center of post) = Ultimate load (post mount) / (34.26 plf x 2.5 safety factor).

² Center-to-center spacing is based on post strength noted in Intertek report No. N8659.01-119-19. Allowable post spacing shall not exceed the lesser of the noted center-to-center post spacing or the allowable length of the guardrail to which it is attached.

³ Withstand load equal to or greater than 225 lbs (Design Load) x 2.5 (safety factor) = 563 lbs.

⁴ Maximum guardrail height is 42 in; post mounts reported herein have not been evaluated for guardrail heights more than 42 in.

⁵ Requirements are based on the design load and a 2.5 safety factor. The Authority Having Jurisdiction (AHJ) shall determine if the safety factor is adequate for the product and material type.

⁶ Loads were applied in the outward direction only.

TEST REPORT FOR FORTRESS BUILDING PRODUCTS

Report No.: P0710.01-119-19

Date: 11/15/22

Application: All Other Guards ⁶

GUARDRAIL SYSTEM	GUARDRAIL TYPE	BALUSTER	SUPPORT POST ⁴	REQUIREMENTS ⁵	
				CONCENTRATED LOAD ³	UNIFORM LOAD ^{1, 2} ALLOWABLE CENTER-TO-CENTER POST SPACING
A/13 Home w/ Flat or Round ATR	Level / In-Line Application	Vertical Cables with Intermediate Baluster	3 in Square A/13 Home Post Mount	Meets the requirements	6 ft - 3 in

¹ Allowable post spacing (center-to-center of post) = Ultimate load (post mount) / (51.39 plf x 2.5 safety factor).

² Center-to-center spacing is based on post strength noted in Intertek report No. N8659.01-119-19. Allowable post spacing shall not exceed the lesser of the noted center-to-center post spacing or the allowable length of the guardrail to which it is attached.

³ Withstand load equal to or greater than 225 lbs (Design Load) x 2.5 (safety factor) = 563 lbs.

⁴ Maximum guardrail height is 42 in; post mounts reported herein have not been evaluated for guardrail heights more than 42 in.

⁵ Requirements are based on the design load and a 2.5 safety factor. The Authority Having Jurisdiction (AHJ) shall determine if the safety factor is adequate for the product and material type.

⁶ Loads were applied in the outward direction only.

Anchorage of support posts to the supporting structure is not included in the scope of this testing and would need to be evaluated separately.

TEST REPORT FOR FORTRESS BUILDING PRODUCTS

Report No.: P0710.01-119-19

Date: 11/15/22

SECTION 10

PHOTOGRAPHS



Photo No. 1
In-Fill Load Test at Center of Three Cables



Photo No. 2
In-Fill Load Test at Bottom of Three Cables

TEST REPORT FOR FORTRESS BUILDING PRODUCTS

Report No.: P0710.01-119-19

Date: 11/15/22



Photo No. 3
Horizontal Uniform Load on Top Rail



Photo No. 4
Vertical Uniform Load on Top Rail

TEST REPORT FOR FORTRESS BUILDING PRODUCTS

Report No.: P0710.01-119-19

Date: 11/15/22



Photo No. 5

Horizontal Concentrated Load Test at Midspan of Top Rail



Photo No. 6

Vertical Concentrated Load at Midspan of Top Rail

TEST REPORT FOR FORTRESS BUILDING PRODUCTS

Report No.: P0710.01-119-19

Date: 11/15/22



Photo No. 7

Horizontal Concentrated Load at Ends of Rail (Brackets)

SECTION 11 **DRAWINGS**

The "As-Built" drawings for the *A13 Home Vertical Cable Rail* aluminum guardrail system which follow have been reviewed by Intertek B&C and are representative of the project reported herein. Project construction was verified by Intertek B&C per the drawings included in this report. Any deviations are documented herein or on the drawings.

intertek

NOTE: ATR OR WOOD CAP REQUIRED FOR TOP RAIL

Test sample complies with these details.
Deviations are noted.

Report # P0710-01-119-19

Date 10/20/22 Tech AJS

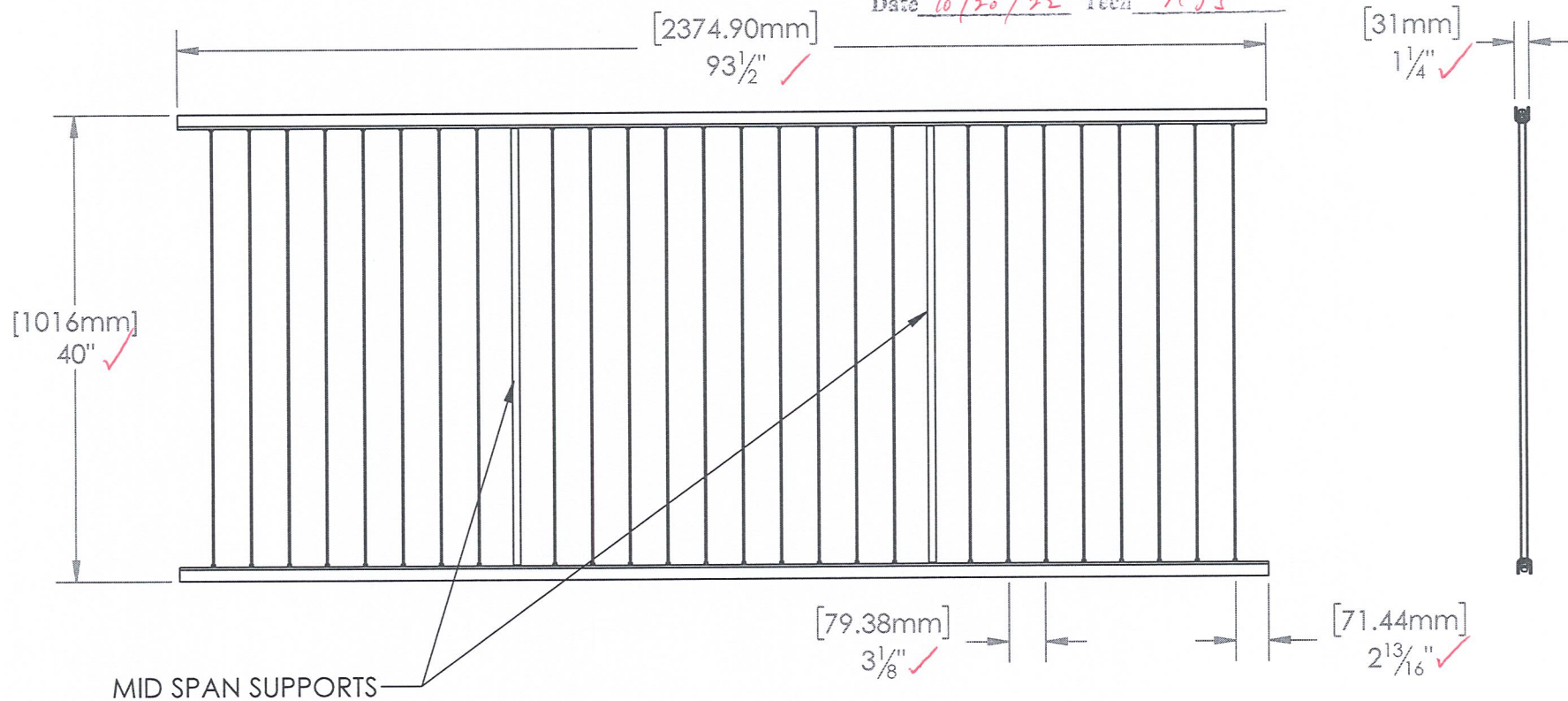

This drawing and the information contained on this drawing are the property of Fortress Iron, LP, Garland, TX, USA, and is not to be copied electronically or manually, or reproduced in any manner, or divulged to other sources, without the expressed written permission of an authorized representative of Fortress Iron, LP.



Fortress Railing
1720 N 1st Street
Garland, Tx 75040

B1	5/17/2018	CW	UPDATED UNITS
REV	DATE	BY	DESCRIPTION
DESCRIPTION: 8' X 40" VERTICAL CABLE PANEL ASSEMBLY			
DRAWN BY: chrisw		SCALE: 1:14	
DATE: 05/10/2018		DIVISION: Fortress Railing	
Sheet: 1 OF 1	ITEM #: 57140808	FILE NAME/PART #: R3336-00359A	REV: B

TITLE: 1 X 19 STAINLESS STEEL CABLE 40'

ITEM NO.	DESCRIPTION	QTY.
1	1 X 19 STAINLESS STEEL CABLE 40"	1

intertek

Test sample complies with these details.
Deviations are noted.

Report # P0710-01-119-19

Date 10/20/22 Tech AJS

SCALE: 1:4

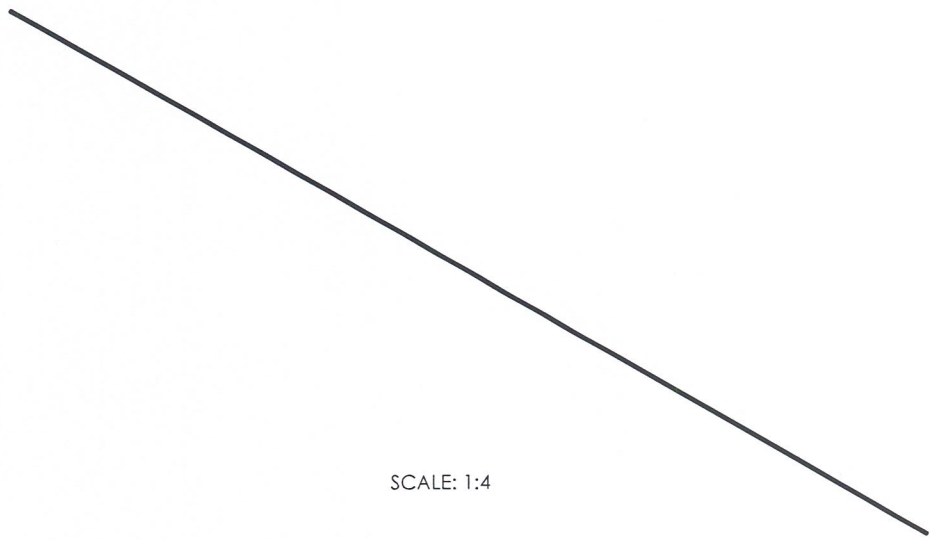
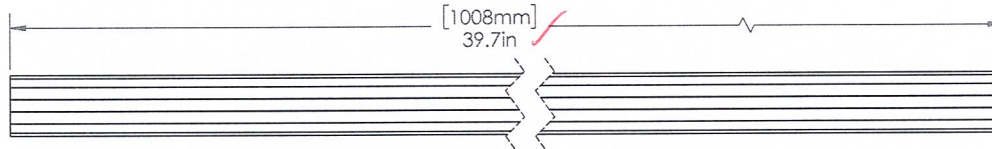
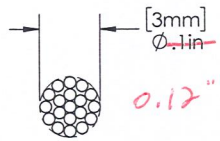

This drawing and the information contained on this drawing are the property of Fortress Iron, LP, Garland, TX, USA, and is not to be copied electronically or manually, or reproduced in any manner, or divulged to other sources, without the expressed written permission of an authorized representative of Fortress Iron, LP.



Fortress Iron, LP
1720 N 1st Street
Garland, Tx 75040
Sheet: 1 OF 1

REV	DATE	BY	DESCRIPTION	SCALE	REV
B	12/17/19	KC	STANDARDIZED		
DESCRIPTION:					
1 X 19 STAINLESS STEEL CABLE 40"					
DRAWN BY: KevinF				4:1	
DATE: 10/07/2022 DIVISION: Fortress Rail					
ITEM #: FILE NAME/PART #:					
R3333-00343A					B

TITLE: VERTICAL CABLE PANEL SPACER 40"

ITEM NO.	PART NUMBER	DESCRIPTION	QTY.
1	R3331-00345	VERTICAL CABLE PANEL SPACER 40"	1

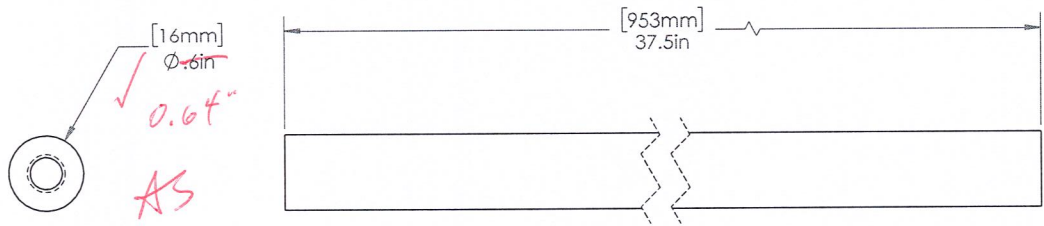

intertek

Test sample complies with these details.
Deviations are noted.

Report # 10710-01-119-19

Date 10/20/22 Tech ATS

SCALE: 1:6

This drawing and the information contained on this drawing are the property of Fortress Iron, LP, Garland, TX, USA, and is not to be copied electronically or manually, or reproduced in any manner, or divulged to other sources, without the expressed written permission of an authorized representative of Fortress Iron, LP.

FORTRESS
BUILDING PRODUCTS

Fortress Iron, LP
1720 N 1st Street
Garland, Tx 75040

Sheet: 1 OF 1

REV	DATE	BY	DESCRIPTION	SCALE:
C	12/17/19	KC	STANDARDIZED	1:1
DESCRIPTION:				REV:
VERTICAL CABLE PANEL SPACER 40"				C
DRAWN BY: KevinF		DIVISION: Fortress Rail		
DATE: 10/07/2022		FILE NAME/PART #:		
ITEM #:		R3331-00345A		

intertek

Test sample complies with these details.
Deviations are noted.

Report # P0710-01-119-19

Date 10/20/22 Tech AJS

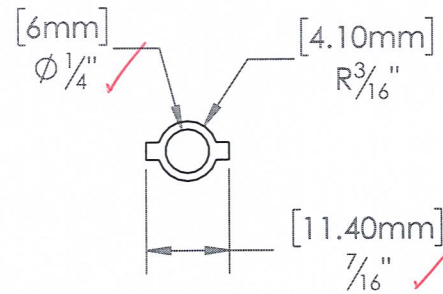
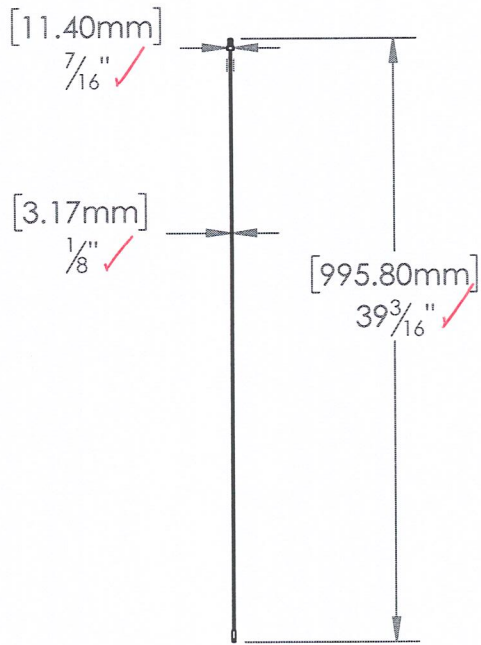

This drawing and the information contained on this drawing are the property of Fortress Iron, LP, Garland, TX, USA, and is not to be copied electronically or manually, or reproduced in any manner, or divulged to other sources, without the expressed written permission of an authorized representative of Fortress Iron, LP.



Fortress Railing
1720 N 1st Street
Garland, Tx 75040

5	04/28/2020	TF	Initial Drawing
REV	DATE	BY	DESCRIPTION
DESCRIPTION: AL13 HOME VERTICAL CABLE SWAGE ASSEMBLY 40"			
DRAWN BY: TylerF		SCALE: AS SHOWN	
DATE: 04/28/2020		DIVISION: Fortress Rail	
Sheet: 1 OF 1	ITEM #:	FILE NAME/PART #: A13 HOME Vertical Cable 40in	REV: 5

intertek

Test sample complies with these details.
Deviations are noted.

Report # P0710-01-119-19

Date 10/20/22 Tech AJS

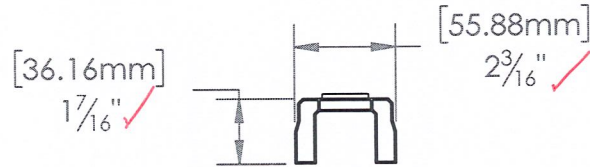
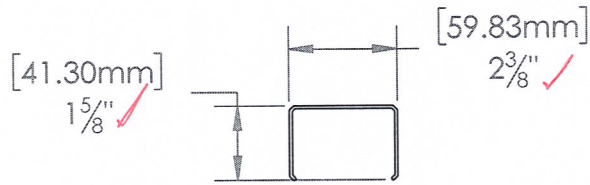

SECTION A-A
SCALE 1 : 4

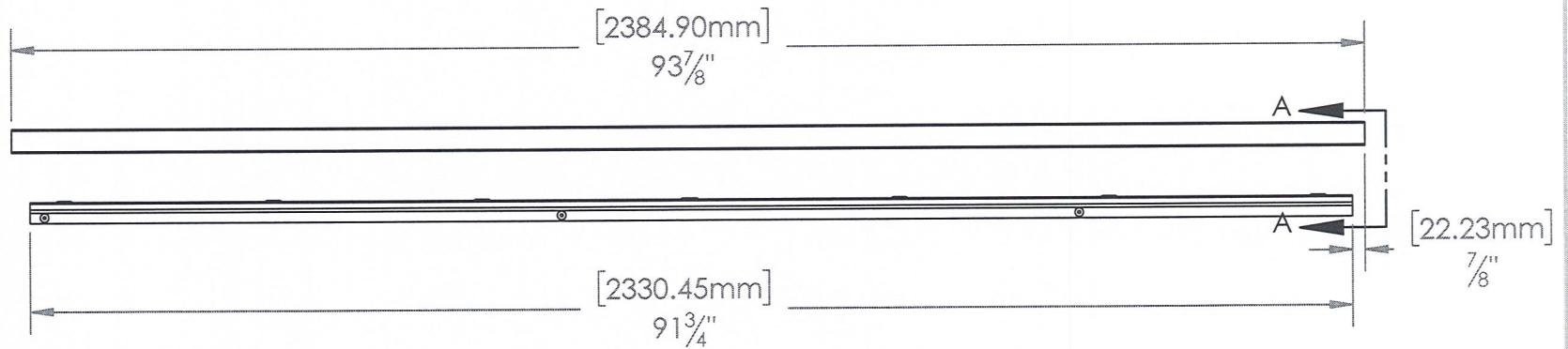
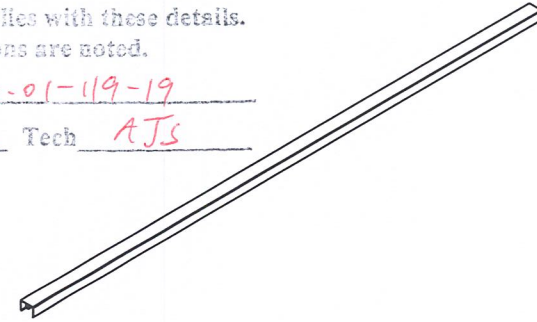

This drawing and the information contained on this drawing are the property of Fortress Iron, LP, Garland, TX, USA, and is not to be copied electronically or manually, or reproduced in any manner, or divulged to other sources, without the expressed written permission of an authorized representative of Fortress Iron, LP.

FORTRESS
—RAILING PRODUCTS—

Fortress Railing
1720 N 1st Street
Garland, Tx 75040

A	02/06/20	TF	Initial Drawing
REV	DATE	BY	DESCRIPTION
DESCRIPTION: A113 HOME 93.89" - 8' FLAT ATR KIT			
DRAWN BY: TylerF		SCALE: 1:12	
DATE: 02/06/2020		DIVISION: Fortress Rail	
ITEM #:	FILE NAME/PART #:	REV: A	
Sheet: 1 OF 1	FLAT ATR KIT WITH FULL LENGTH SPACER		

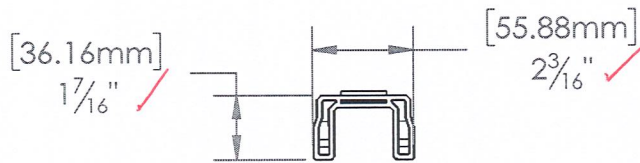
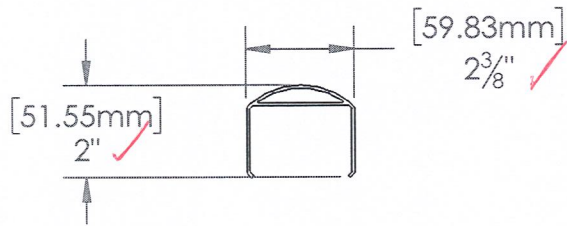

SECTION A-A
SCALE 1 : 4

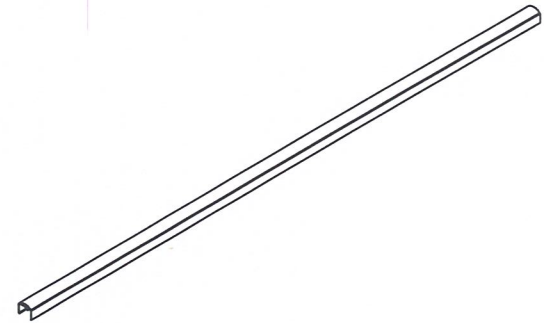
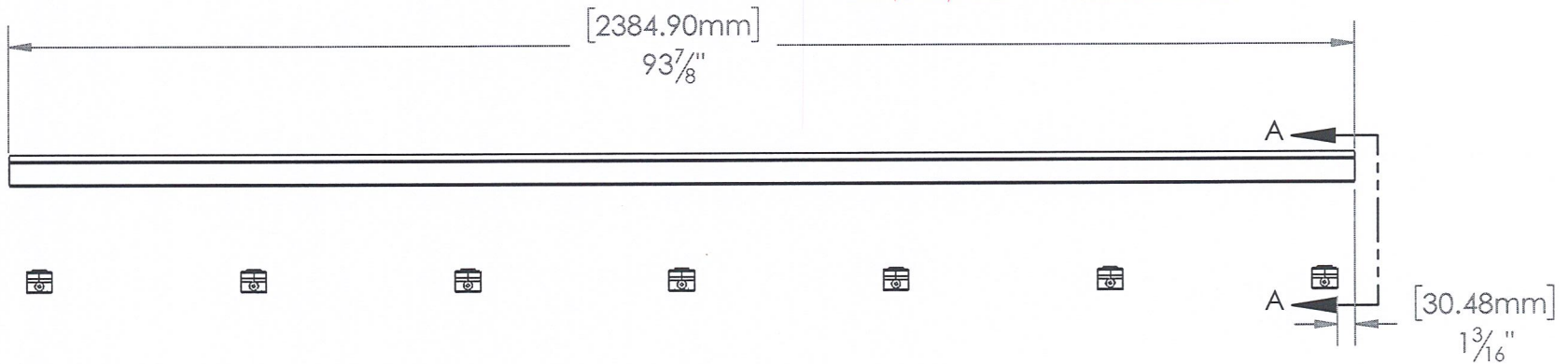

intertek

Test sample complies with these details.
Deviations are noted.

Report # P0710.01-49-19

Date 10/20/22 Tech AJS

This drawing and the information contained on this drawing are the property of Fortress Iron, LP, Garland, TX, USA, and is not to be copied electronically or manually, or reproduced in any manner, or divulged to other sources, without the expressed written permission of an authorized representative of Fortress Iron, LP.



Fortress Railing
1720 N 1st Street
Garland, Tx 75040

Sheet: 1 OF 1

REV	DATE	BY	DESCRIPTION	SCALE:
A	02/06/20	TF	Initial Drawing	1:12
DESCRIPTION: AI13 HOME 93.89" - 8' ROUND ATR KIT				
DRAWN BY: TylerF			DIVISION: Fortress Rail	
DATE: 02/06/2020			SCALE: 1:12	
ITEM #: FILE NAME/PART #: ROUND ATR KIT WITH SHORT SPACERS				REV: A

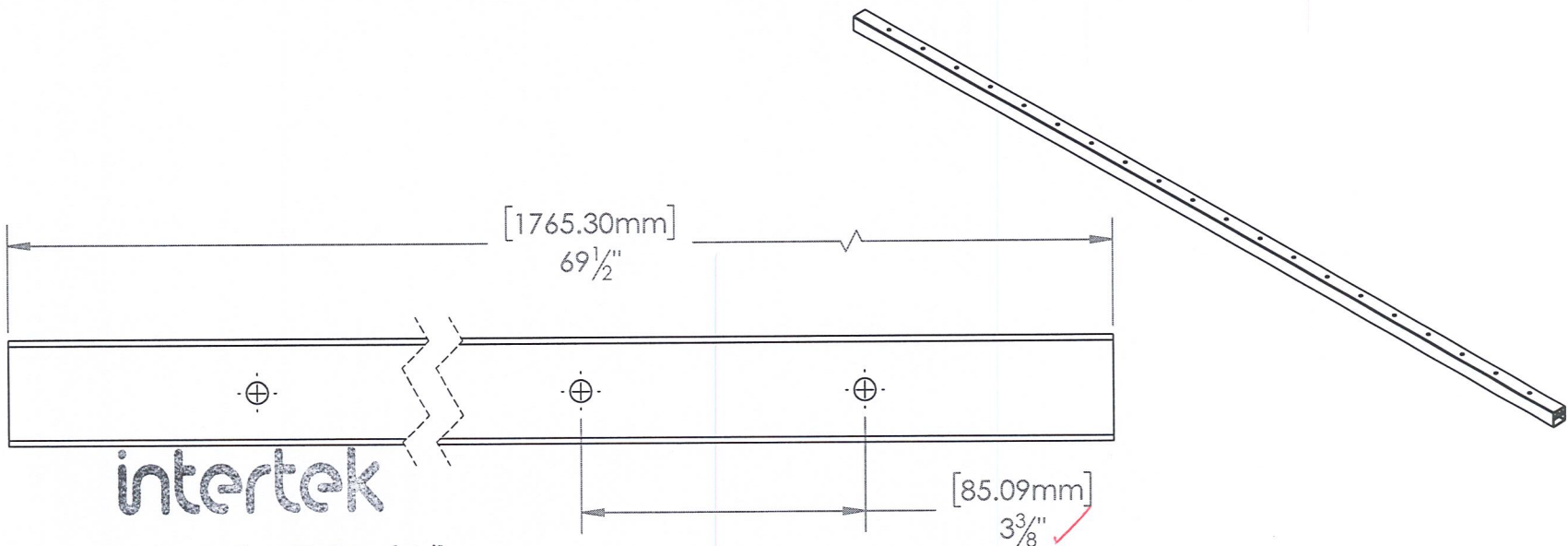

intertek

Test sample complies with these details.
Deviations are noted.

Report # P0710-01-119-19

Date 10/20/22 Tech AJS

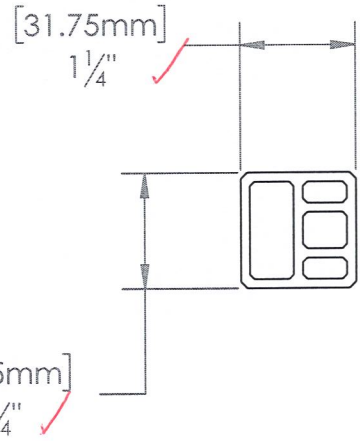
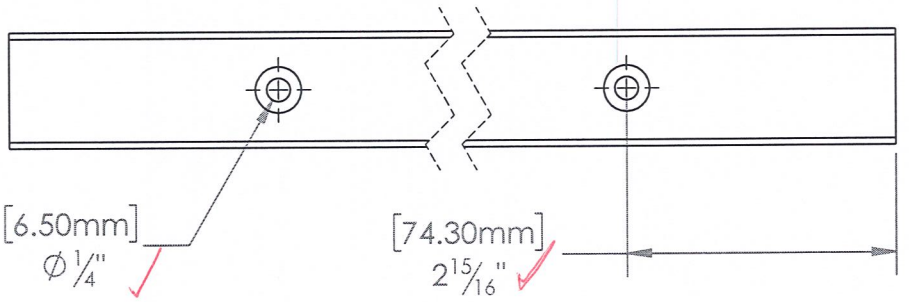

This drawing and the information contained on this drawing are the property of Fortress Iron, LP, Garland, TX, USA, and is not to be copied electronically or manually, or reproduced in any manner, or divulged to other sources, without the expressed written permission of an authorized representative of Fortress Iron, LP.

FORTRESS
— RAILING PRODUCTS —

Fortress Railing
1720 N 1st Street
Garland, Tx 75040

Sheet: 1 OF 1

4	07/10/2020	TF	Initial Drawing
REV	DATE	BY	DESCRIPTION
DESCRIPTION: AL13 HOME VERTICAL CABLE BOTTOM RAIL 6'			
DRAWN BY: KevinF		SCALE: AS SHOWN	
DATE: 07/10/2020		DIVISION: Fortress Rail	
ITEM #:	FILE NAME/PART #:	REV:	
	R3931-10332A	4	

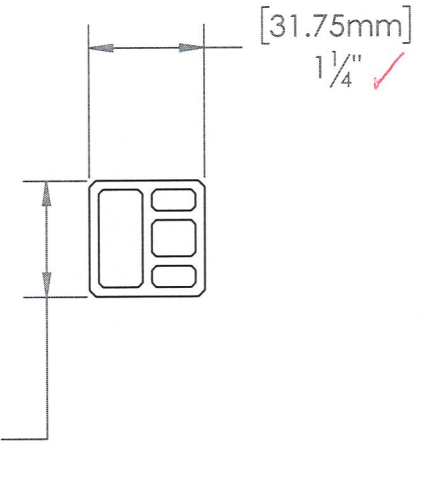
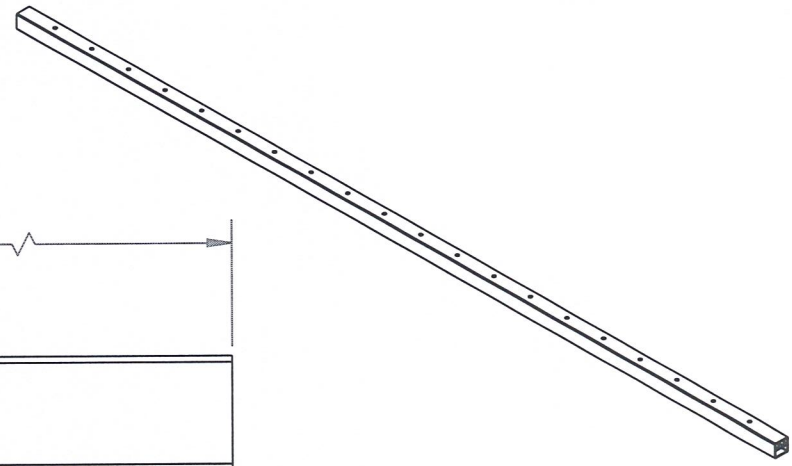
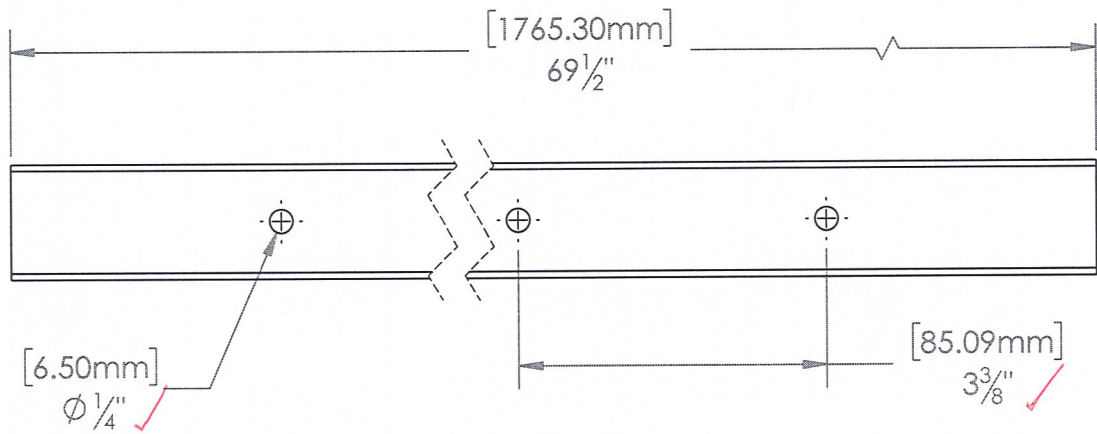

intertek

Test sample complies with these details.
Deviations are noted.
Report # P0710.01-119-19
Date 10/20/22 Tech AJS

This drawing and the information contained on this drawing are the property of Fortress Iron, LP, Garland, TX, USA, and is not to be copied electronically or manually, or reproduced in any manner, or divulged to other sources, without the expressed written permission of an authorized representative of Fortress Iron, LP.

FORTRESS
— RAILING PRODUCTS —

Fortress Railing
1720 N 1st Street
Garland, Tx 75040

3	07/10/2020	TF	Initial Drawing
REV	DATE	BY	DESCRIPTION
DESCRIPTION: AL13 HOME VERTICAL CABLE TOP RAIL 6'			
DRAWN BY: KevinF		SCALE: AS SHOWN	
DATE: 07/10/2020		DIVISION: Fortress Rail	
ITEM #:	FILE NAME/PART #:	REV:	
Sheet: 1 OF 1	R3931-10331A	3	



Total Quality. Assured.

130 Derry Court
York, Pennsylvania 17406

Telephone: 717-764-7700
Facsimile: 717-764-4129
www.intertek.com/building

TEST REPORT FOR FORTRESS BUILDING PRODUCTS

Report No.: P0710.01-119-19

Date: 11/15/22

SECTION 12

REVISION LOG

REVISION #	DATE	PAGES	REVISION
0	11/15/22	N/A	Original Report Issue